

# SB SERIES

## INSTRUCTION MANUAL

### Preface

Thank you for purchasing the CONVU Programmable Signal Conditioner SB series. This manual contains instructions for the mounting, functions, operations and notes for operating the SB series. For model confirmation and unit specifications, please read this manual carefully before starting operation.

**To prevent accidents arising from the misuse of this instrument, please ensure the operator receives this manual.**

### Notes

- This instrument should be used in accordance with the specifications described in the manual. If it is not used according to the specifications, it may malfunction or cause fire.
- Be sure to follow the warnings, cautions and notices. If they are not observed, serious injury or accidents may occur.
- The contents of this instruction manual are subject to change without notice.
- Care has been taken to assure that the contents of this instruction manual are correct, but if there are any doubts, mistakes or questions, please inform our sales department.
- This instrument is designed to be installed on a DIN rail. Measures must be taken to ensure that power terminals or other high voltage sections cannot be touched.
- Any unauthorized transfer or copying of this document, in part or in whole, is prohibited.
- Shinko Technos Co., Ltd. is not liable for any damages or secondary damages incurred as a result of using this product, including any indirect damages.

### Safety Precautions (Be sure to read this before using units)

The safety precautions are classified into categories: "Warning" and "Caution". Depending on circumstances, procedures indicated by ⚠ Caution may be linked to serious results, so be sure to follow the directions for usage.

**⚠ Warning** Procedures which may lead to dangerous conditions and cause death or serious injury, if not carried out properly.

**⚠ Caution** Procedures which may lead to dangerous conditions and cause superficial to medium injury or physical damage or may degrade or damage the product, if not carried out properly.

#### ⚠ Warning

- To prevent an electric shock or fire, only Shinko or qualified service personnel may handle the inner assembly.
- To prevent an electric shock, fire or damage to instrument, parts replacement may only be undertaken by Shinko or qualified service personnel.

#### ⚠ Safety precautions

- To ensure safe and correct use, thoroughly read and understand this manual before using this instrument.
- This instrument is intended to be used for industrial machinery, machine tools and measuring equipment. Verify correct usage after consulting purpose of use with our agency or main office. (Never use this instrument for medical purposes with which human lives are involved.)
- External protection devices must be installed, as malfunction of this product could result in serious damage to the system or injury to personnel. Also proper periodic maintenance is required.
- This instrument must be used under the conditions and environment described in this manual. Shinko Technos Co., Ltd. does not accept liability for any injury, loss of life or damage occurring due to the instrument being used under conditions not otherwise stated in this manual.

#### Caution with respect to Export Trade Control Ordinance

To avoid this instrument from being used as a component in, or as being utilized in the manufacture of weapons of mass destruction (i.e. military applications, military equipment, etc.), please investigate the end users and the final use of this instrument. In the case of resale, ensure that this instrument is not illegally exported.

### ● Installation precautions

#### ⚠ Caution

This instrument is intended to be used under the following environmental conditions (IEC61010-1): Overvoltage category II, Pollution degree 2. Ensure the mounting location corresponds to the following conditions:

- A minimum of dust, and an absence of corrosive gases
- No flammable or explosive gases
- No mechanical vibrations or shocks
- No exposure to direct sunlight, an ambient temperature of -5 to 55°C (23 to 131°F) that does not change rapidly
- An ambient non-condensing humidity of 35 to 85%RH
- No large capacity electromagnetic switches or cables through which large current flows
- No water, oil or chemicals or where the vapors of these substances can come into direct contact with the unit

**Note:** Do not install this instrument near flammable material even though the case of this instrument is made of flame resistant resin. Avoid setting this instrument directly on flammable material.

### ● Wiring precautions

#### ⚠ Caution

- Do not leave bits of wire in the instrument, because they could cause fire and malfunction.
- When wiring terminals, use ferrules with an insulation sleeve and crimping pliers made by Phoenix Contact GMBH & CO. applicable to terminals.
- This instrument has no built-in power switch, circuit breaker or fuse. It is necessary to install them near the instrument. (Recommended fuse: Time-lag fuse, rated voltage 250V AC, rated current 2A)
- For wiring of AC power source, be sure to use exclusive terminals as described in this manual. If AC power source is connected to incorrect terminals, the unit will burn out.
- For a DC power supply, do not confuse polarity.
- Do not apply a commercial power source to the sensor connected to the input terminal nor allow the power source to come into contact with the sensor, as the input circuit may burn out.
- Use a thermocouple, compensating lead wire and 3-wire system RTD according to the sensor input specifications of this unit.
- When using DC voltage and current input, do not confuse polarity when wiring.
- Keep the input wire (TC, RTD, etc.) and power line away from each other.

### ● Running and maintenance precautions

#### ⚠ Caution

- Do not touch live terminals. This may cause electric shock or problems in operation.
- Turn the power supply to the instrument OFF before cleaning. Working or touching the terminal with the power switched ON may result in severe injury or death due to Electric Shock.
- Use a soft, dry cloth when cleaning the instrument. (Alcohol based substances may tarnish or deface the unit.)

## 1. Name and functions of the sections

### ● SBA, SBV, SBE, SBR, SBD

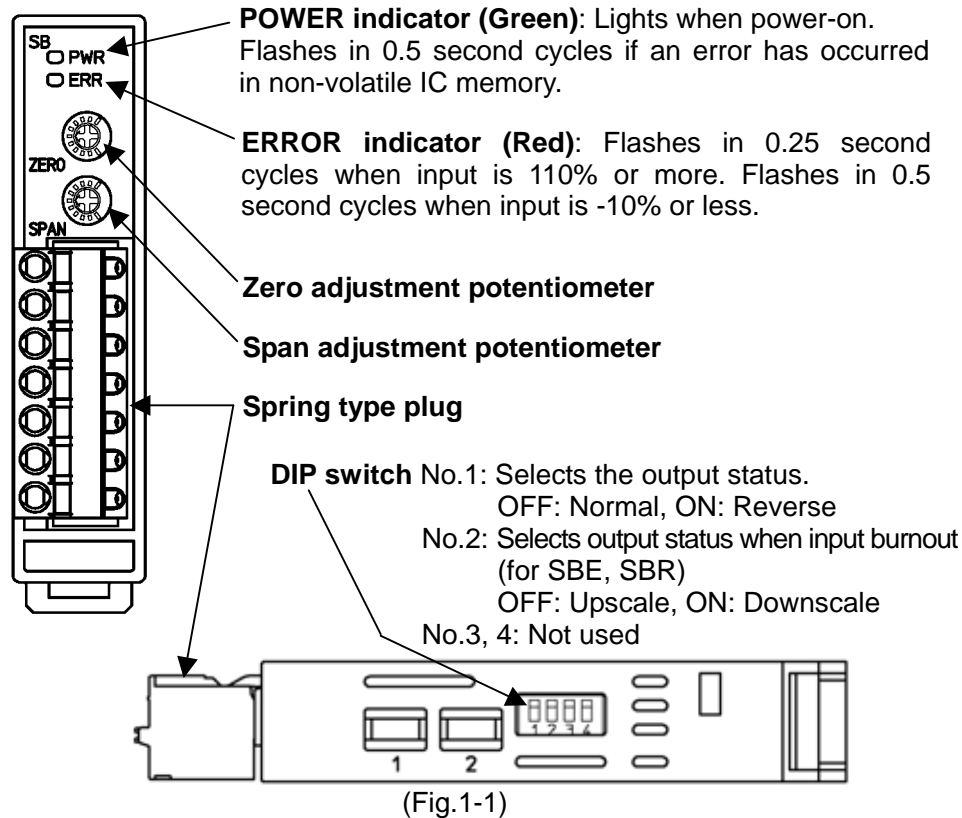

### ● SBP

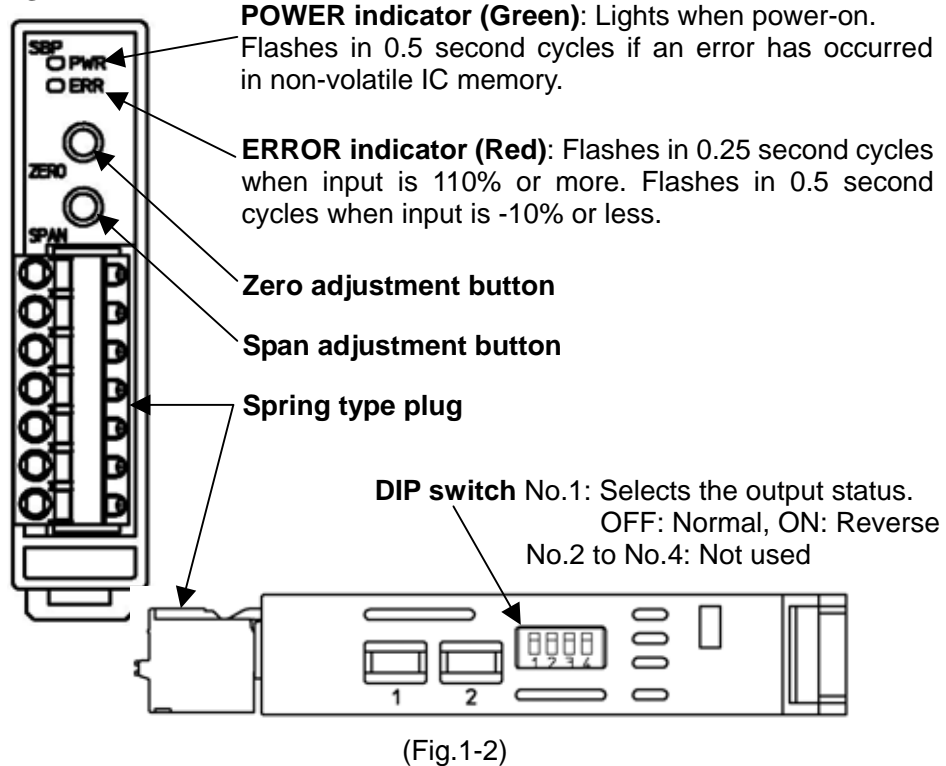

## 2. Mounting

### 2.1 External dimensions (unit: mm)

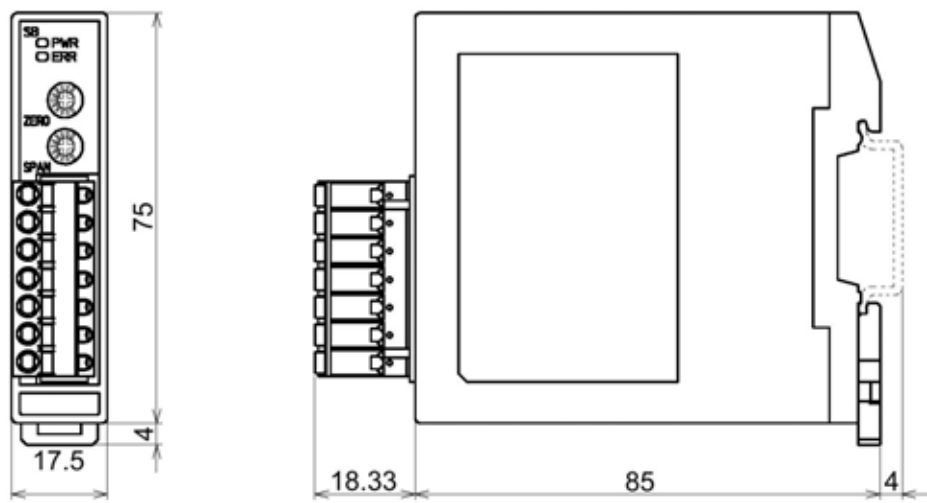

(Fig. 2.1-1)

### 2.2 Mounting to DIN rail

#### ⚠ Notice

- Mount the DIN rail laterally.
- The following shows DIN rail corresponding to the SB series. (Fig. 2.2-1)

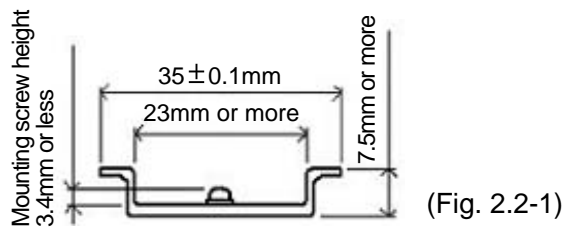

(Fig. 2.2-1)

- To fix this unit, use commercially available fastening plates at both ends of the unit.

#### Fastening plates

Omron Corporation	End plate	PFP-M
IDEC Corporation	Fastening plate	BNL6P, BNL8P
Matsushita Electric Works, LTD.	Fastening plate	ATA4806

- Do not confuse the top and bottom of this unit.
- When mounting to or removing the unit from the DIN rail, the units must be slanted a little. Therefore do not mount any other instruments within 50mm of space at the upside and downside from the unit, considering wiring space and radiation.

- Pull the lock lever of the unit down (1), hook the unit to the DIN rail at an angle of approx. 20 degrees upward (2) and mount it (3).

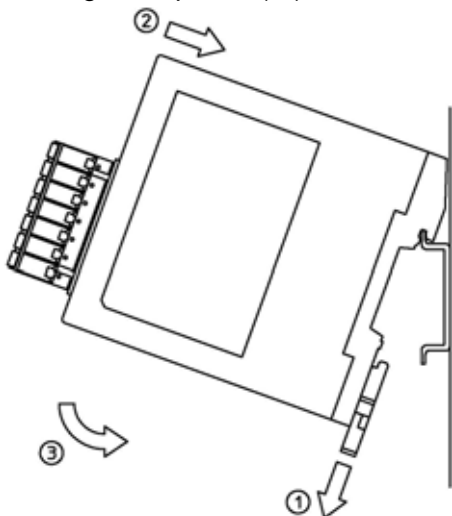

(Fig. 2.2-2)

- Push the lock lever of the unit up until a clicking sound is heard (4).

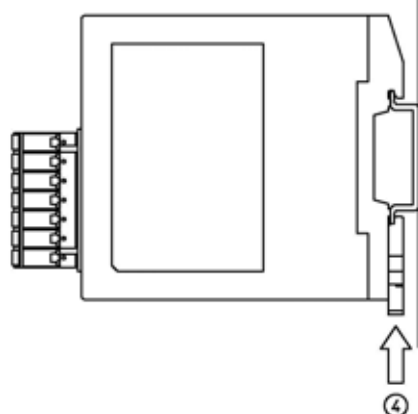

(Fig. 2.2-3)

- Be sure to use end plates (model: AEP-001-1) at both ends of the unit.

## 3. Wiring

When using ferrules, use the following recommended ferrules and crimping pliers made by Phoenix Contact GMBH & CO. (Table 3-1)

(Table 3-1)

Ferrules with insulation sleeve	Conductor cross sections	Crimping pliers
AI 0.25-6 BU	0.2 to 0.25mm <sup>2</sup>	CRIMPFOX ZA 3 CRIMPFOX UD 6
AI 0.34-8 TQ	0.25 to 0.34mm <sup>2</sup>	
AI 0.5-8 WH	0.34 to 0.5mm <sup>2</sup>	
AI 0.75-8 GY	0.5 to 0.75mm <sup>2</sup>	
AI 1.0-8 RD	0.75 to 1.0mm <sup>2</sup>	
AI 1.5-8 BK	1.0 to 1.5mm <sup>2</sup>	
AI 2.5-8 BU	1.5 to 2.5mm <sup>2</sup>	

For terminal wiring, refer to the following. (Fig. 3-1, Fig. 3-2)

#### ● SBA, SBV, SBE, SBR, SBP

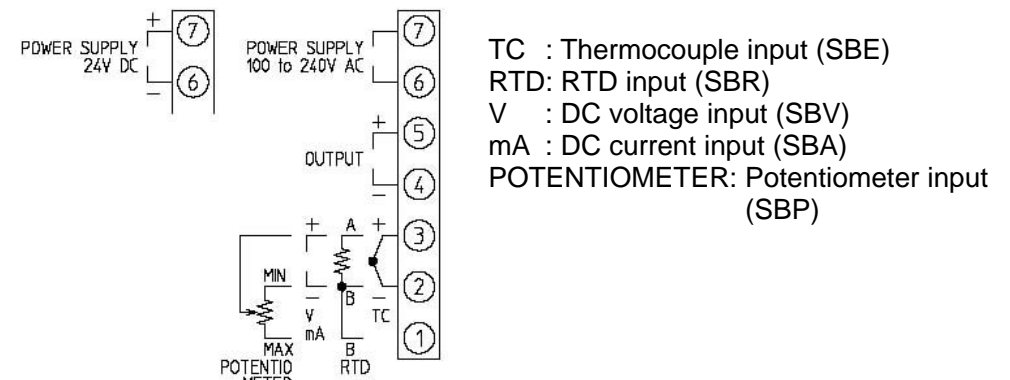

(Fig. 3-1)

#### ● SBD

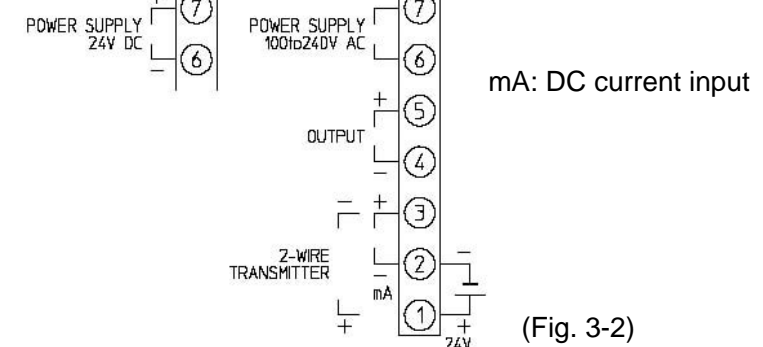

(Fig. 3-2)

For spring type plug, insert the wire while pressing the lever (orange color) with a flat blade screwdriver. (Fig. 3-3)

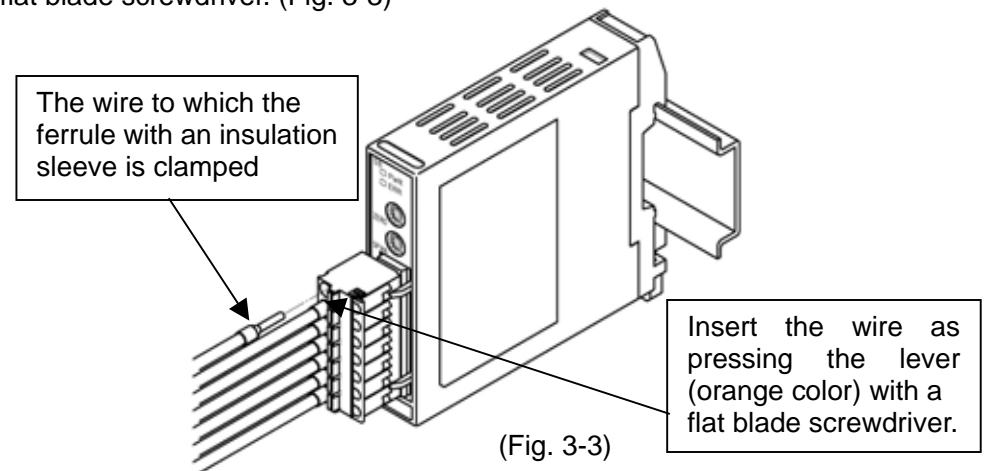

(Fig. 3-3)

## 4. Adjustment

The output of this unit has been already adjusted when shipped. Therefore, it is not required to adjust the unit in the case users use it with the ordered Input/Output specification.

However, in the case of fine adjustment or calibration between connected units, adjust the value following the procedures described below.

Connect an mV generator or Dial resistor to the input terminals of this unit. Connect a digital multimeter to output terminals.

For SBP, register Zero and Span position after connecting a potentiometer.

#### ● SBA, SBV, SBE, SBR, SBD (zero, span adjustment)

- Input the Output 0% value, then adjust the value by turning the potentiometer for zero adjustment, while viewing the output value (digital multimeter indication).
- Input the Output 100% value, then adjust the value by turning the potentiometer for span adjustment, while viewing the output value (digital multimeter indication).
- Input the Output 0% value again, and check the output value (digital multimeter indication).
- If Output 0% value is not at 0%, repeat steps from (1) to (3) until output % value is 0.

#### ● SBP (zero, span registration)

- Set the potentiometer to the MIN side, then press the Zero adjustment button for approximately 2 seconds. Automatic adjustment begins, then Zero position will be registered.
- Set the potentiometer to the MAX side, then press the Span adjustment button for approximately 2 seconds. Automatic adjustment begins, then Span position will be registered.

## Inquiry

For any inquiry about this unit, please contact the shop where you purchased the unit or our agency after checking the following.

(e.g.)

- Model ----- SBA-0101-0
- Serial number ----- No.123456

In addition to the above, please let us know the details of malfunction, if any, and the operating conditions.

**Shinko**  
North America Ltd.

25 Whitefriars Drive  
Toronto ON, Canada M3A 2L2  
Tel: 416 444-0817  
Fax: 416 444-2361  
Toll Free: 1 - 866-4SHINKO