

To prevent accidents arising from the misuse of this instrument, please ensure the operator receives this manual.

SAFETY PRECAUTIONS

- To ensure safe and correct use, thoroughly read and understand this manual before using this instrument.
- This instrument is intended to be used for industrial machinery, machine tools and measuring equipment. Verify correct usage after consulting purpose of use with our agency or main office. (Never use this instrument for medical purposes with which human lives are involved.)
- External protection devices such as protection equipment against excessive temperature rise, etc. must be installed, as malfunction of this product could result in serious damage to the system or injury to personnel. Also proper periodic maintenance is required.
- This instrument must be used under the conditions and environment described in this manual. Shinko Technos Co., Ltd. does not accept liability for any injury, loss of life or damage occurring due to the instrument being used under conditions not otherwise stated in this manual.

Caution with respect to Export Trade Control Ordinance

To avoid this instrument from being used as a component in, or as being utilized in the manufacture of weapons of mass destruction (i.e. military applications, military equipment, etc.), please investigate the end users and the final use of this instrument. In the case of resale, ensure that this instrument is not illegally exported.

Caution

- This instrument should be used in accordance with the specifications described in the manual. If it is not used according to the specifications, it may malfunction or cause fire.
- Be sure to follow the warnings, cautions and notices. Not doing so could cause serious injury or malfunction.
- Specifications of the JIR-301-M and the contents of this instruction manual are subject to change without notice.
- This instrument is designed to be installed within a control panel. If this is not the case, measures must be taken to ensure that the operator cannot touch power terminals or other high voltage sections.
- Be sure to turn the power supply to the instrument OFF before cleaning this instrument.
- Use a soft and dry cloth when cleaning the instrument. (If paint thinner is used, it might deform or tarnish the unit.)
- As the display section is vulnerable, do not strike or scratch it with a hard object.
- Any unauthorized transfer or copying of this document, in part or in whole, is prohibited.
- Shinko Technos CO., LTD. is not liable for any damages or secondary damages incurred as a result of using this product, including any indirect damages.

Characters used in this manual

Indication	-	0	1	2	3	4	5	6	7	8	9	C	F
Number, °C/°F	-1	0	1	2	3	4	5	6	7	8	9	°C	°F
Indication	A	b	c	d	E	F	G	H	I	J	k	L	ā
Alphabet	A	B	C	D	E	F	G	H	I	J	K	L	M
Indication	n	o	P	q	r	s	t	U	v	w	x	y	z
Alphabet	N	O	P	Q	R	S	T	U	V	W	X	Y	Z

1. Model

1.1 Model

JIR-301-M <input type="checkbox"/> , <input type="checkbox"/> <input type="checkbox"/> <input type="checkbox"/>		Series name: JIR-301-M (W96 x H48 x D100mm)		
Input	M	Multi-range *1		
Power supply		100 to 240V AC (standard)		
	1	24V AC/DC *2		
Option	TA *3	Specified transmission output	DC current output	0 to 20mA DC
	TV		DC voltage output	0 to 1V DC 0 to 5V DC 1 to 5V DC 0 to 10V DC
	C5	Serial communication (RS-485) *4		
	P24	Insulated power output *5		
	BK	Color, Black		
	TC	Terminal cover		

A1, A2 and A3 alarm outputs are provided as standard for the JIR-301-M.

Alarm actions (5 types and No alarm action) and Energized/Deenergized can be selected by keypad.

*1: An input type can be selected out of TC (10 types), RTD (2 types), DC current (2 types) and DC voltage (4 types) by keypad.

*2: Supply voltage 100 to 240V AC is standard. When ordering 24V AC/DC, enter "1" after the input code.

*3: **TA (4 to 20mA DC) is equipped as standard.**

*4: If the Serial communication option is added, HOLD function is not available.

*5: If the Insulated power output option is added, A2 output cannot be added.

1.2 How to read the model label

Model labels are attached to the case and the inner assembly.

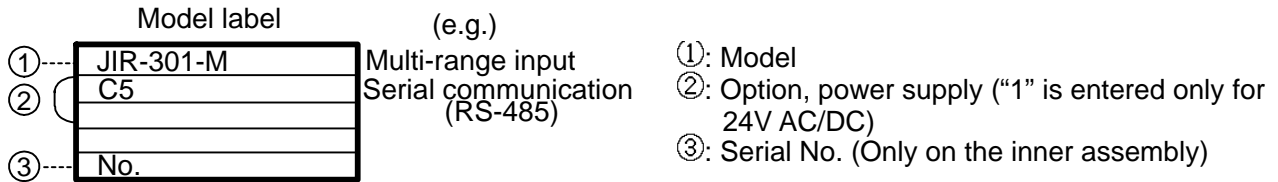

2. Name and functions of the sections

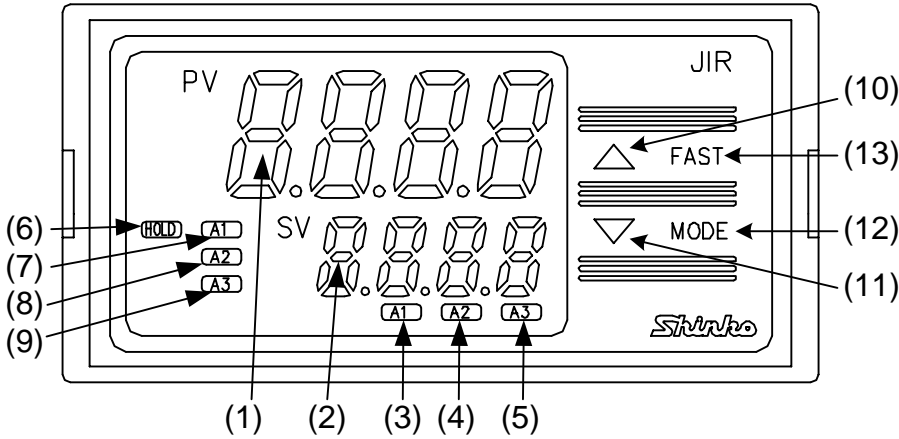

- (1) **PV display**: Indicates the input value with a red LED.
- (2) **SV display**: Indicates the main set value with a green LED.
- (3) **A1 action indicator**: When A1 output is ON, a red LED lights.
- (4) **A2 action indicator**: When A2 output is ON, a red LED lights.
- (5) **A3 action indicator**: When A3 output is ON, a red LED lights.
- (6) **HOLD indicator**: When PV HOLD (Hold, Peak hold, Bottom hold) output is ON, a yellow LED lights up.
- (7) **A1 indicator**: When A1 value is indicated, a green LED lights.
- (8) **A2 indicator**: When A2 value is indicated, a green LED lights.
- (9) **A3 indicator**: When A3 value is indicated, a green LED lights.
- (10) **Increase key** : Increases the numeric value.
- (11) **Decrease key** : Decreases the numeric value.
- (12) **MODE key** : Selects the setting mode or registers the set value.
(To register the set value or selected value, press the MODE key)
- (13) **FAST key** : Makes the set value change faster while holding down Increase or Decrease key together.



Notice

When setting the specifications and functions of this instrument, connect terminals 2 and 3 for power source first, then set them referring to "5. Setup" before performing "3. Mounting to the control panel" and "4. Wiring".

3. Mounting to the control panel

3.1 Site selection

This instrument is intended to be used under the following environmental conditions (IEC61010-1): Overvoltage category II, Pollution degree 2

Ensure the mounting location corresponds to the following conditions:

- A minimum of dust, and an absence of corrosive gases
- No flammable, explosive gases
- Few mechanical vibrations or shocks
- No exposure to direct sunlight, an ambient temperature of 0 to 50°C (32 to 122°F) that does not change rapidly
- An ambient non-condensing humidity of 35 to 85%RH
- No large capacity electromagnetic switches or cables through which large current is flowing
- No water, oil or chemicals or where the vapors of these substances can come into direct contact with the instrument

3.2 External dimensions (Unit: mm)

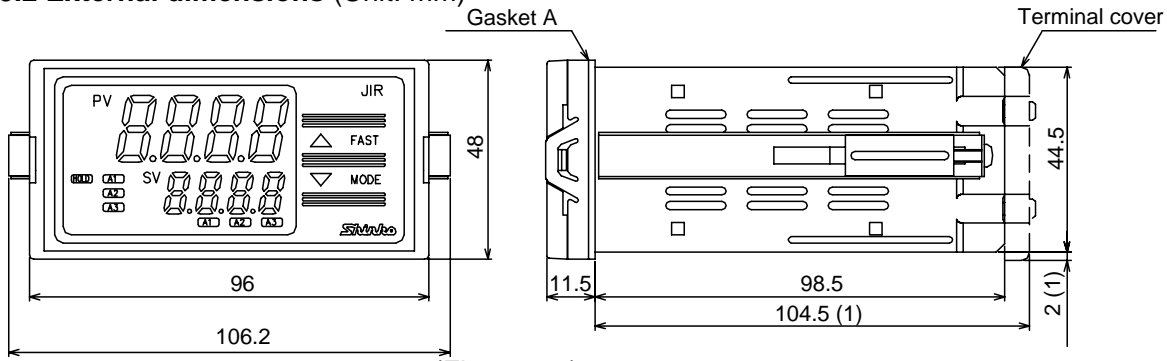

(Fig. 3.2-1)

3.3 Panel cutout (Unit: mm)

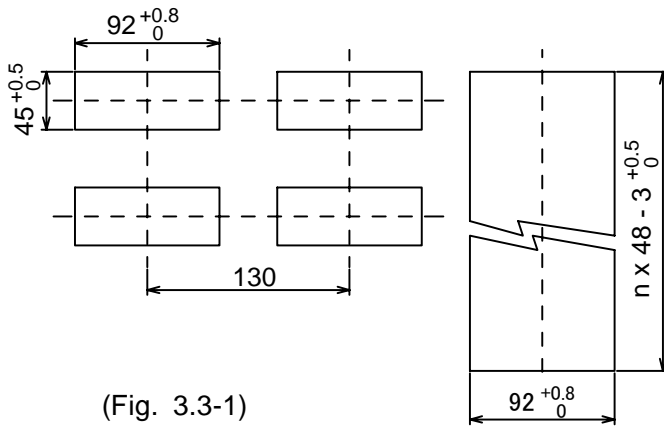

(Fig. 3.3-1)

Lengthwise close mounting
n: Number of units mounted

⚠Caution: If lengthwise close mounting is used for the instrument, IP66 (Dust-proof/Drip-proof) may be compromised, and all warranties will be invalidated.

3.4 Mounting

Mount the instrument vertically to ensure that it adheres to the Dust-proof/Drip-proof specification (IP66).

Mountable panel thickness: 1 to 15mm

Insert the instrument from the front side of the panel.

Attach the screw type mounting brackets by the holes at the top and bottom of the case, and secure the instrument in place with the screws.

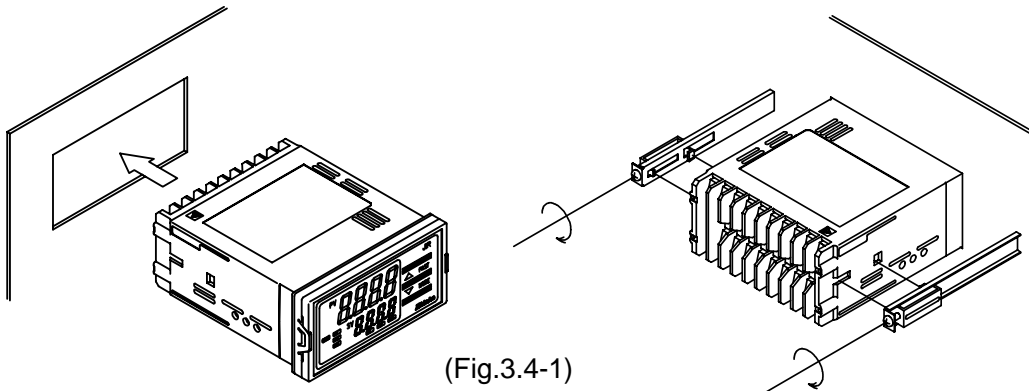

(Fig.3.4-1)

⚠ Warning

As the case is made of resin, do not use excessive force while screwing in the mounting bracket, or the case or screw type mounting bracket could be damaged.
The torque is approximately 0.12N•m.

4. Wiring

⚠ Warning

Turn the power supply to the instrument off before wiring or checking it.
Working or touching the terminal with the power switched on may result in severe injury or death due to Electric Shock.

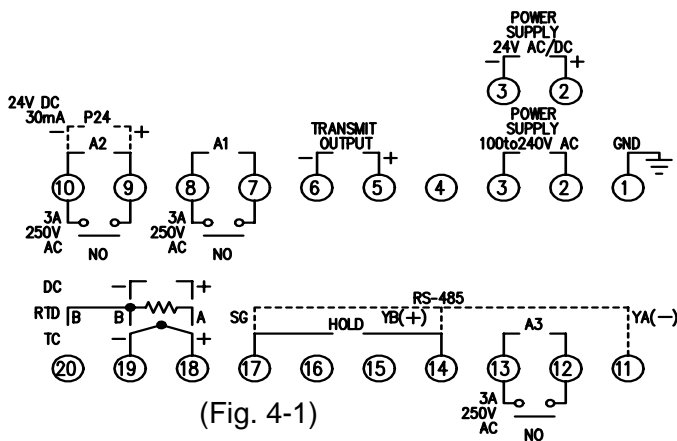

- GND : Ground terminal
- A1 : Alarm 1 output
- A2 : Alarm 2 output
- A3 : Alarm 3 output
- TRANSMIT OUTPUT: Transmission output
- P24 : Insulated power output
- HOLD : HOLD function
- RS-485: Serial communication (RS-485)
- TC : Thermocouple
- RTD : Resistance temperature detector
- DC : DC current, DC voltage
- Dotted lines: Options.

(Fig. 4-1)

Notice

- The terminal block of the JIR-301-M is designed to be wired from the upper side. The lead wire must be inserted from the upper side of the terminal, and fastened by the terminal screw.
- Use a thermocouple and compensating lead wire in accordance with the sensor input specification of this instrument.
- Use the 3-wire RTD which corresponds to the input specification of this instrument.
- This instrument does not have built-in power switch, circuit breaker or fuse. Therefore, it is necessary to install them in the circuit near the external instrument. (Recommended fuse: Time-lag fuse, rated voltage 250V AC, rated current 2A)
- **For a 24V AC/DC power source, do not confuse polarity when using direct current (DC).**
- When using a relay contact output type, externally use a relay according to the capacity of the load to protect the built-in relay contact.
- When wiring, keep input wires (thermocouple, RTD, etc.) away from AC sources or load wires to avoid external interference.
- Do not apply a commercial power source to the sensor connected to the input terminal nor allow the power source to come into contact with the sensor.

Lead wire solderless terminal

Use a solderless terminal with an insulation sleeve in which an M3 screw fits as shown below.

Solderless terminal	Manufacturer	Model	Tightening torque
Y type	Nichifu Terminal Industries CO.,LTD.	1.25Y-3	0.6N•m
	Japan Solderless Terminal MFG CO.,LTD.	VD1.25-B3A	Max.
Round type	Nichifu Terminal Industries CO.,LTD.	1.25-3	1.0N•m
	Japan Solderless Terminal MFG CO.,LTD.	V1.25-3	

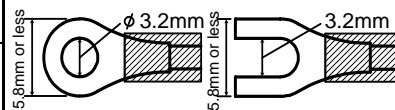

(Fig. 4-2)

5. Setup

Wire the power terminals only. After the power is turned on, the sensor input characters and temperature unit are indicated on the PV display, and the input range high limit value is indicated on the SV display for approx. 3sec. (Table 5-1) (If any other value is set during the Scaling high limit setting, the set value is indicated on the SV display) During this time, all outputs and the LED indicators are in an OFF status. Indication will then start, and the input value will be indicated on the PV display, and alarm value will be indicated on the SV display.

Sensor input	PV display ^{°C}	SV display	PV display ^{°F}	SV display
K	e . C	1310	e . F	2500
	e . C	4000	e . F	7500
J	J . C	1000	J . F	1800
R	r . C	1760	r . F	3200
S	s . C	1760	s . F	3200
B	b . C	1820	b . F	3300
E	E . C	800	E . F	1500
T	r . C	4000	r . F	7500
N	n . C	1300	n . F	2300
PL-II	PL2C	1390	PL2F	2500
C (W/Re5-26)	e . C	2315	e . F	4200
	Pf . C	8500	Pf . F	9999
Pt100	Pf . C	850	Pf . F	1500
	JPf . C	5000	JPf . F	9000
JPt100	JPf . C	500	JPf . F	900
4 to 20mA DC	420A		420A	
0 to 20mA DC	020A		020A	
0 to 1V DC	0 18	Scaling high limit value	0 18	Scaling high limit value
0 to 5V DC	0 58		0 58	
1 to 5V DC	1 58		1 58	
0 to 10V DC	0 108		0 108	

(Table 5-1)

5.1 Operation flowchart

[PV/SV display mode]

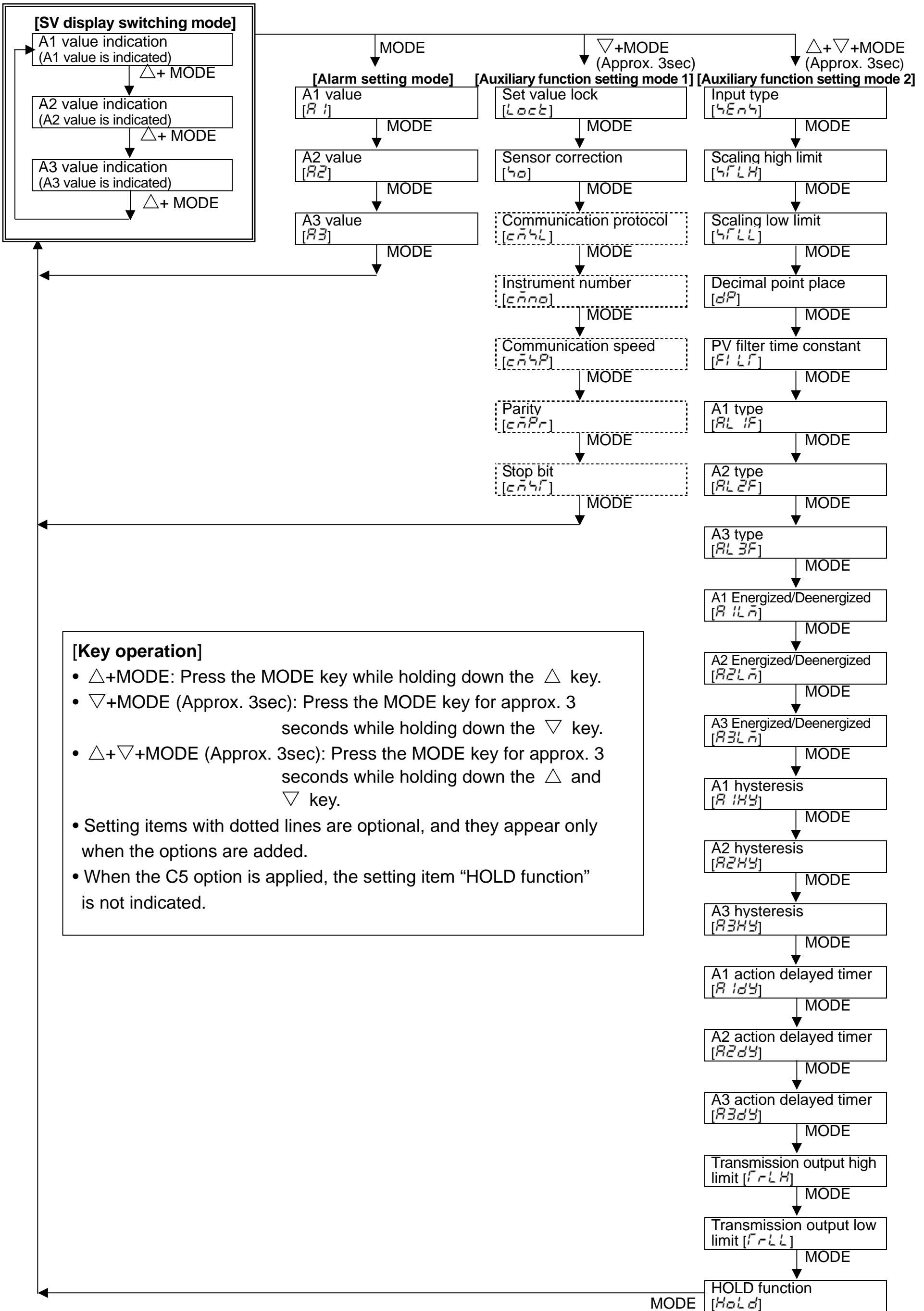

5.2 Alarm setting mode

Character	Name, Function, Setting range	Default value
<i>A1</i>	A1 value setting <ul style="list-style-type: none"> • Sets A1 output action point. • Not available if No alarm action is selected during A1 type selection. • Refer to (Table 5.2-1). 	0°C
<i>A2</i>	A2 value setting <ul style="list-style-type: none"> • Sets A2 output action point. • Not available if the Insulated power output option is applied, or if No alarm action is selected during A2 type selection. • Refer to (Table 5.2-1). 	0°C
<i>A3</i>	A3 value setting <ul style="list-style-type: none"> • Sets A3 output action point. • Not available if No alarm action or High/Low limit range alarm is selected during A3 type selection. • Refer to (Table 5.2-1). 	0°C

(Table 5.2-1)

Alarm type	Setting range
High limit alarm	Input range low limit to input range high limit value
Low limit alarm	Input range low limit to input range high limit value
High limit alarm with standby	Input range low limit to input range high limit value
Low limit alarm with standby	Input range low limit to input range high limit value
High/Low limit range alarm *1	None

- The placement of the decimal point follows the selection or input rating.
 - When input has a decimal point, the negative low limit value is -199.9, and the positive high limit value is 999.9.
 - Setting range of DC current and DC voltage input: Scaling low limit to Scaling high limit value.
- *1: High/Low limit range alarm is available only for A3. If High/Low limit range alarm is selected, the setting items which are related to A3 (A3 value, A3 action Energized/Deenergized, A3 hysteresis, A3 action delayed timer) will not be indicated.

5.3 SV display switching mode

Name, Function	Default value
A1 value indication <ul style="list-style-type: none"> • A1 value is indicated on the SV display, and A1 indicator lights. • Not available if No alarm action is selected during A1 type selection. 	0°C
A2 value indication <ul style="list-style-type: none"> • A2 value is indicated on the SV display, and A2 indicator lights. • Not available if the Insulated power output option is applied, or if No alarm action is selected during A2 type selection. 	0°C
A3 value indication <ul style="list-style-type: none"> • A3 value is indicated on the SV display, and A3 indicator lights. • Not available if No alarm action is selected during A3 type selection, or if High/Low limit range alarm is selected. 	0°C

5.4 Auxiliary function setting mode 1

Character	Name, Function, Setting range	Default value
<i>Loct</i>	Set value lock selection <ul style="list-style-type: none"> • Locks the set values to prevent setting errors. The setting item to be locked depends on the selection. • --- (Unlock): All set values can be changed. • <i>Loct1</i> (Lock 1): None of the set values can be changed. • <i>Loct2</i> (Lock 2): Only main set value can be changed. • <i>Loct3</i> (Lock 3): All set values can be changed. However, do not change the setting items in the Auxiliary function setting mode 2. They return to their previous value after power is turned off because they are not saved in the non-volatile memory. 	Unlock
<i>Co</i>	Sensor correction setting <ul style="list-style-type: none"> • Sets the correction value for the sensor. • Setting range: -100.0 to 100.0°C (°F), or -1000 to 1000 	0.0°C
<i>cncl</i>	Communication protocol selection <ul style="list-style-type: none"> • Selects the communication protocol. • Available only when the Serial communication option is applied. • Shinko protocol: <i>cncl</i>. Modbus ASCII mode: <i>cnclA</i>, Modbus RTU mode: <i>cnclR</i> 	Shinko protocol

<i>cñno</i>	Instrument number setting <ul style="list-style-type: none"> • Sets the instrument number individually to each instrument when communicating by connecting plural instruments in Serial communication. • Available only when the Serial communication option is added. • Setting range: 0 to 95 	0
<i>cñ4P</i>	Communication speed selection <ul style="list-style-type: none"> • Selects a speed to be equal to that of the host computer. • Available only when the Serial communication option is added. • 2400bps: <i>24</i>, 4800bps: <i>48</i>, 9600bps: <i>96</i>, 19200bps: <i>192</i> 	9600bps
<i>cñPr</i>	Parity selection <ul style="list-style-type: none"> • Selects the parity. • Not available if the Serial communication option is not added, or if Shinko protocol is selected during the Communication protocol selection. • No parity: <i>none</i>, Even parity: <i>EBEn</i>, Odd parity: <i>odd</i> 	Even
<i>cñ4I</i>	Stop bit selection <ul style="list-style-type: none"> • Selects the stop bit. • Not available if the Serial communication option is not added, or if Shinko protocol is selected during the Communication protocol selection. • Setting range: 1, 2 	1

5.5 Auxiliary function setting mode 2

Character	Name, Function, Setting range	Default value																																																																																				
<i>4En4</i>	Input type selection <ul style="list-style-type: none"> • The input type can be selected from thermocouple (10 types), RTD (2 types), DC current (2 types) and DC voltage (4 types), and the unit °C/°F can be selected as well. • When changing the input from DC voltage to other inputs, remove the sensor connected to this instrument first, then change for the input. If the input is changed with the sensor connected, the input circuit may break. 	K (-200 to 1370°C)																																																																																				
	<table border="0"> <tr> <td>K</td> <td>-200 to 1370°C: <i>t C</i></td> <td>K</td> <td>-320 to 2500°F: <i>t F</i></td> </tr> <tr> <td></td> <td>-199.9 to 400.0°C: <i>t .C</i></td> <td></td> <td>-199.9 to 750.0°F: <i>t .F</i></td> </tr> <tr> <td>J</td> <td>-200 to 1000 °C: <i>J C</i></td> <td>J</td> <td>-320 to 1800 °F: <i>J F</i></td> </tr> <tr> <td>R</td> <td>0 to 1760 °C: <i>r C</i></td> <td>R</td> <td>0 to 3200 °F: <i>r F</i></td> </tr> <tr> <td>S</td> <td>0 to 1760 °C: <i>s C</i></td> <td>S</td> <td>0 to 3200 °F: <i>s F</i></td> </tr> <tr> <td>B</td> <td>0 to 1820 °C: <i>b C</i></td> <td>B</td> <td>0 to 3300 °F: <i>b F</i></td> </tr> <tr> <td>E</td> <td>-200 to 800 °C: <i>E C</i></td> <td>E</td> <td>-320 to 1500 °F: <i>E F</i></td> </tr> <tr> <td>T</td> <td>-199.9 to 400.0°C: <i>T C</i></td> <td>T</td> <td>-199.9 to 750.0°F: <i>T F</i></td> </tr> <tr> <td>N</td> <td>-200 to 1300 °C: <i>n C</i></td> <td>N</td> <td>-320 to 2300 °F: <i>n F</i></td> </tr> <tr> <td>PL-II</td> <td>0 to 1390 °C: <i>PL2C</i></td> <td>PL-II</td> <td>0 to 2500 °F: <i>PL2F</i></td> </tr> <tr> <td>C (W/Re5-26)</td> <td>0 to 2315 °C: <i>c C</i></td> <td>C (W/Re5-26)</td> <td>0 to 4200 °F: <i>c F</i></td> </tr> <tr> <td>Pt100</td> <td>-199.9 to 850.0°C: <i>Pt C</i></td> <td>Pt100</td> <td>-199.9 to 999.9°F: <i>Pt F</i></td> </tr> <tr> <td>JPt100</td> <td>-199.9 to 500.0°C: <i>JPt C</i></td> <td>JPt100</td> <td>-199.9 to 900.0°F: <i>JPt F</i></td> </tr> <tr> <td>Pt100</td> <td>-200 to 850 °C: <i>Pt C</i></td> <td>Pt100</td> <td>-300 to 1500°F: <i>Pt F</i></td> </tr> <tr> <td>JPt100</td> <td>-200 to 500 °C: <i>JPt C</i></td> <td>JPt100</td> <td>-300 to 900 °F: <i>JPt F</i></td> </tr> <tr> <td>4 to 20mA DC</td> <td>-1999 to 9999: <i>420A</i></td> <td></td> <td></td> </tr> <tr> <td>0 to 20mA DC</td> <td>-1999 to 9999: <i>020A</i></td> <td></td> <td></td> </tr> <tr> <td>0 to 1V DC</td> <td>-1999 to 9999: <i>0 1V</i></td> <td></td> <td></td> </tr> <tr> <td>0 to 5V DC</td> <td>-1999 to 9999: <i>0 5V</i></td> <td></td> <td></td> </tr> <tr> <td>1 to 5V DC</td> <td>-1999 to 9999: <i>1 5V</i></td> <td></td> <td></td> </tr> <tr> <td>0 to 10V DC</td> <td>-1999 to 9999: <i>0 10V</i></td> <td></td> <td></td> </tr> </table>	K	-200 to 1370°C: <i>t C</i>	K	-320 to 2500°F: <i>t F</i>		-199.9 to 400.0°C: <i>t .C</i>		-199.9 to 750.0°F: <i>t .F</i>	J	-200 to 1000 °C: <i>J C</i>	J	-320 to 1800 °F: <i>J F</i>	R	0 to 1760 °C: <i>r C</i>	R	0 to 3200 °F: <i>r F</i>	S	0 to 1760 °C: <i>s C</i>	S	0 to 3200 °F: <i>s F</i>	B	0 to 1820 °C: <i>b C</i>	B	0 to 3300 °F: <i>b F</i>	E	-200 to 800 °C: <i>E C</i>	E	-320 to 1500 °F: <i>E F</i>	T	-199.9 to 400.0°C: <i>T C</i>	T	-199.9 to 750.0°F: <i>T F</i>	N	-200 to 1300 °C: <i>n C</i>	N	-320 to 2300 °F: <i>n F</i>	PL-II	0 to 1390 °C: <i>PL2C</i>	PL-II	0 to 2500 °F: <i>PL2F</i>	C (W/Re5-26)	0 to 2315 °C: <i>c C</i>	C (W/Re5-26)	0 to 4200 °F: <i>c F</i>	Pt100	-199.9 to 850.0°C: <i>Pt C</i>	Pt100	-199.9 to 999.9°F: <i>Pt F</i>	JPt100	-199.9 to 500.0°C: <i>JPt C</i>	JPt100	-199.9 to 900.0°F: <i>JPt F</i>	Pt100	-200 to 850 °C: <i>Pt C</i>	Pt100	-300 to 1500°F: <i>Pt F</i>	JPt100	-200 to 500 °C: <i>JPt C</i>	JPt100	-300 to 900 °F: <i>JPt F</i>	4 to 20mA DC	-1999 to 9999: <i>420A</i>			0 to 20mA DC	-1999 to 9999: <i>020A</i>			0 to 1V DC	-1999 to 9999: <i>0 1V</i>			0 to 5V DC	-1999 to 9999: <i>0 5V</i>			1 to 5V DC	-1999 to 9999: <i>1 5V</i>			0 to 10V DC	-1999 to 9999: <i>0 10V</i>			
K	-200 to 1370°C: <i>t C</i>	K	-320 to 2500°F: <i>t F</i>																																																																																			
	-199.9 to 400.0°C: <i>t .C</i>		-199.9 to 750.0°F: <i>t .F</i>																																																																																			
J	-200 to 1000 °C: <i>J C</i>	J	-320 to 1800 °F: <i>J F</i>																																																																																			
R	0 to 1760 °C: <i>r C</i>	R	0 to 3200 °F: <i>r F</i>																																																																																			
S	0 to 1760 °C: <i>s C</i>	S	0 to 3200 °F: <i>s F</i>																																																																																			
B	0 to 1820 °C: <i>b C</i>	B	0 to 3300 °F: <i>b F</i>																																																																																			
E	-200 to 800 °C: <i>E C</i>	E	-320 to 1500 °F: <i>E F</i>																																																																																			
T	-199.9 to 400.0°C: <i>T C</i>	T	-199.9 to 750.0°F: <i>T F</i>																																																																																			
N	-200 to 1300 °C: <i>n C</i>	N	-320 to 2300 °F: <i>n F</i>																																																																																			
PL-II	0 to 1390 °C: <i>PL2C</i>	PL-II	0 to 2500 °F: <i>PL2F</i>																																																																																			
C (W/Re5-26)	0 to 2315 °C: <i>c C</i>	C (W/Re5-26)	0 to 4200 °F: <i>c F</i>																																																																																			
Pt100	-199.9 to 850.0°C: <i>Pt C</i>	Pt100	-199.9 to 999.9°F: <i>Pt F</i>																																																																																			
JPt100	-199.9 to 500.0°C: <i>JPt C</i>	JPt100	-199.9 to 900.0°F: <i>JPt F</i>																																																																																			
Pt100	-200 to 850 °C: <i>Pt C</i>	Pt100	-300 to 1500°F: <i>Pt F</i>																																																																																			
JPt100	-200 to 500 °C: <i>JPt C</i>	JPt100	-300 to 900 °F: <i>JPt F</i>																																																																																			
4 to 20mA DC	-1999 to 9999: <i>420A</i>																																																																																					
0 to 20mA DC	-1999 to 9999: <i>020A</i>																																																																																					
0 to 1V DC	-1999 to 9999: <i>0 1V</i>																																																																																					
0 to 5V DC	-1999 to 9999: <i>0 5V</i>																																																																																					
1 to 5V DC	-1999 to 9999: <i>1 5V</i>																																																																																					
0 to 10V DC	-1999 to 9999: <i>0 10V</i>																																																																																					
<i>4FLH</i>	Scaling high limit setting <ul style="list-style-type: none"> • Sets scaling high limit value. • Available only for DC input • Setting range: Scaling low limit value to Input range high limit value 	9999																																																																																				
<i>4FLl</i>	Scaling low limit setting <ul style="list-style-type: none"> • Sets scaling low limit value. • Available only for DC input • Setting range: Input range low limit value to Scaling high limit value 	-1999																																																																																				
<i>dP</i>	Decimal point place selection <ul style="list-style-type: none"> • Selects decimal point place. • Available only for DC input • No decimal point: <i>0000</i> 1 digit after decimal point: <i>0000</i> 2 digits after decimal point: <i>00.00</i> 3 digits after decimal point: <i>000.00</i> 	No decimal point																																																																																				

<i>F1LF</i>	PV filter time constant setting <ul style="list-style-type: none"> • Sets PV filter time constant. (If the value is set too large, it affects alarm action due to the delay of response) • Setting range: 0.0 to 10.0 seconds 	0.0 seconds
<i>RL1F</i>	A1 type selection <ul style="list-style-type: none"> • Selects an A1 type. No alarm action : <i>----</i> High limit alarm : <i>H</i> High limit alarm with standby: <i>H</i> <i>u</i> Low limit alarm : <i>L</i> Low limit alarm with standby: <i>L</i> <i>u</i>	No alarm action
<i>RL2F</i>	A2 type selection <ul style="list-style-type: none"> • Selects an A2 type. • Not available if the Insulated power output option is added • Type selection and default value are the same as those of A1 type selection. 	No alarm action
<i>RL3F</i>	A3 type selection <ul style="list-style-type: none"> • Selects an A3 type. No alarm action: <i>----</i> High limit alarm: <i>H</i> Low limit alarm : <i>L</i> High limit alarm with standby : <i>H</i> <i>u</i> Low limit alarm with standby : <i>L</i> <i>u</i> High/Low limit range alarm : <i>u</i> <i>d</i> <ul style="list-style-type: none"> • High/Low limit range alarm is activated depending on A1 and A2 values. If both A1 and A2 are turned OFF, A3 is turned ON in combination with A1 High limit alarm (High limit alarm with standby) and A2 Low limit alarm (Low limit alarm with standby), or in combination with A1 Low limit alarm (Low limit alarm with standby) and A2 High limit alarm (High limit alarm with standby). • If High/Low limit range alarm is selected, A3 related setting items (A3 value, A3 action Energized/Deenergized, A3 hysteresis, A3 action delayed timer) are not available. 	No alarm action
<i>R1LA</i>	A1 action Energized/Deenergized selection <ul style="list-style-type: none"> • Selects Energized/Deenergized for A1. • Not available if No alarm action is selected during A1 type selection • Energized: <i>nonL</i> Deenergized: <i>rEBH</i> 	Energized
<i>R2LA</i>	A2 action Energized/Deenergized selection <ul style="list-style-type: none"> • Selects Energized/Deenergized for A2. • Not available if the Insulated power output option is added, or if No alarm action is selected during A2 type selection • Action selection and default value are the same as those of A1 action Energized/Deenergized selection. 	Energized
<i>R3LA</i>	A3 action Energized/Deenergized selection <ul style="list-style-type: none"> • Selects Energized/Deenergized for A3. • Not available if No alarm action is selected during A3 type selection or if High/Low limit range alarm is selected. • Action selection and default value are the same as those of A1 action Energized/Deenergized selection. 	Energized
<i>R1HY</i>	A1 hysteresis setting <ul style="list-style-type: none"> • Sets hysteresis for A1. • Not available if No alarm action is selected during A1 type selection • Setting range: 0.1 to 100.0°C(°F), or 1 to 1000 	1.0°C
<i>R2HY</i>	A2 hysteresis setting <ul style="list-style-type: none"> • Sets hysteresis for A2. • Not available if the Insulated power output option is added, or if No alarm action is selected during A2 type selection • Setting range: 0.1 to 100.0°C(°F), or 1 to 1000 	1.0°C
<i>R3HY</i>	A3 hysteresis setting <ul style="list-style-type: none"> • Sets hysteresis for A3. • Not available if No alarm action is selected during A3 type selection, or if High/Low limit range alarm is selected. • Setting range: 0.1 to 100.0°C(°F), or 1 to 1000 	1.0°C
<i>R1dY</i>	A1 action delayed timer setting <ul style="list-style-type: none"> • Sets action delayed timer for A1. When setting time has passed after the input enters the alarm output range, the alarm is activated. <ul style="list-style-type: none"> • Not available if No alarm action is selected during A1 type selection • Setting range: 0 to 9999 seconds 	0 seconds

<i>A2dY</i>	A2 action delayed timer setting <ul style="list-style-type: none"> Sets action delayed timer for A2. When setting time has passed after the input enters the alarm output range, the alarm is activated. Not available if the Insulated power output option is added, or if No alarm action is selected during A2 type selection Setting range: 0 to 9999 seconds 	0 seconds										
<i>A3dY</i>	A3 action delayed timer setting <ul style="list-style-type: none"> Sets action delayed timer for A3. When setting time has passed after the input enters the alarm output range, the alarm is activated. Not available if No alarm action is selected during A3 type selection, or if High/Low limit range alarm is selected. Setting range: 0 to 9999 seconds 	0 seconds										
<i>FRLH</i>	Transmission output high limit setting <ul style="list-style-type: none"> Sets the transmission output high limit value. Standard Transmission output: <table border="1"> <tr> <td>4-20mA DC</td> <td>Corresponds to the value at 20mA DC output</td> </tr> </table> Optional Transmission output: <table border="1"> <tr> <td>0-20mA DC</td> <td>Corresponds to the value at 20mA DC output</td> </tr> <tr> <td>0-1V DC</td> <td>Corresponds to the value at 1V DC output</td> </tr> <tr> <td>0-5V DC, 1-5V DC</td> <td>Corresponds to the value at 5V DC output</td> </tr> <tr> <td>0-10V DC</td> <td>Corresponds to the value at 10V DC output</td> </tr> </table> <ul style="list-style-type: none"> Setting range: Transmission output low limit value to input range high limit value 	4-20mA DC	Corresponds to the value at 20mA DC output	0-20mA DC	Corresponds to the value at 20mA DC output	0-1V DC	Corresponds to the value at 1V DC output	0-5V DC, 1-5V DC	Corresponds to the value at 5V DC output	0-10V DC	Corresponds to the value at 10V DC output	1370°C
4-20mA DC	Corresponds to the value at 20mA DC output											
0-20mA DC	Corresponds to the value at 20mA DC output											
0-1V DC	Corresponds to the value at 1V DC output											
0-5V DC, 1-5V DC	Corresponds to the value at 5V DC output											
0-10V DC	Corresponds to the value at 10V DC output											
<i>FRL</i>	Transmission output low limit setting <ul style="list-style-type: none"> Sets the transmission output low limit value. Standard Transmission output: <table border="1"> <tr> <td>4-20mA DC</td> <td>Corresponds to the value at 4mA DC output</td> </tr> </table> Optional Transmission output: <table border="1"> <tr> <td>0-20mA DC</td> <td>Corresponds to the value at 0mA DC output</td> </tr> <tr> <td>0-1V DC, 0-5V DC</td> <td>Corresponds to the value at 0V DC output</td> </tr> <tr> <td>0-10V DC</td> <td></td> </tr> <tr> <td>1-5V DC</td> <td>Corresponds to the value at 1V DC output</td> </tr> </table> <ul style="list-style-type: none"> Setting range: Input range low limit value to transmission output high limit value 	4-20mA DC	Corresponds to the value at 4mA DC output	0-20mA DC	Corresponds to the value at 0mA DC output	0-1V DC, 0-5V DC	Corresponds to the value at 0V DC output	0-10V DC		1-5V DC	Corresponds to the value at 1V DC output	-200°C
4-20mA DC	Corresponds to the value at 4mA DC output											
0-20mA DC	Corresponds to the value at 0mA DC output											
0-1V DC, 0-5V DC	Corresponds to the value at 0V DC output											
0-10V DC												
1-5V DC	Corresponds to the value at 1V DC output											
<i>Hold</i>	HOLD function selection <ul style="list-style-type: none"> 3 types of HOLD function can be selected. Not available if the Serial communication option is added [How to use HOLD function] <p>Connect terminals 14 and 17 to use HOLD function.</p> <ul style="list-style-type: none"> HOLD: PV at the given time is held and indicated. Peak HOLD: The updated maximum PV is indicated. Bottom HOLD: The updated minimum PV is indicated. 	HOLD										

Sensor correction function

This corrects the input value from the sensor. When a sensor cannot be set at the exact location where control is desired, the sensor measured temperature may deviate from the temperature in the controlled location. When controlling with plural JIR-301-M units, sometimes the measured temperatures (input value) do not concur due to difference in sensor accuracy or dispersion of load capacities. In such a case, the control can be set at the desired temperature by adjusting the input value of sensors.

Energized/Deenergized

When [alarm action Energized] is selected, A1 (A2, A3) output (between terminals 7-8, 9-10, 12-13) is conducted (ON) while A1 (A2, A3) action indicator is lit.

A1 (A2, A3) output is not conducted (OFF) while A1 (A2, A3) action indicator is not lit.

When [alarm action Deenergized] is selected, A1 (A2, A3) output (between terminals 7-8, 9-10, 12-13) is not conducted (OFF) while A1 (A2, A3) action indicator is lit.

A1 (A2, A3) output is conducted (ON) while A1 (A2, A3) action indicator is not lit.

High limit alarm (when Energized is set)

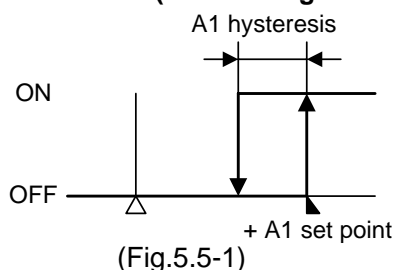

High limit alarm (when Deenergized is set)

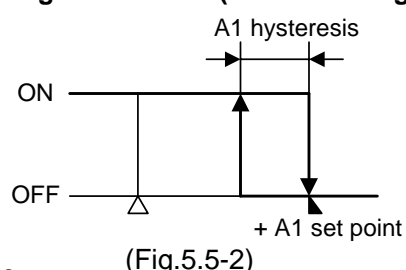

6. Running

After the JIR-301-M is mounted to the control panel and wiring is completed, operate the unit following the procedures below.

(1) Turn the power supply to the JIR-301-M ON.

Turn the power supply to the JIR-301-M ON.

- For approx. 3sec after the power is switched ON, the sensor input characters and the temperature unit are indicated on the PV display, and input range high limit value is indicated on the SV display. See (Table 5-1).

(If any other value has been set during the Scaling high limit setting, the set value is indicated on the SV display)

During this time, all outputs and LED indicators are in an OFF status.

- After that, input value is indicated on the PV display, and alarm value is indicated on the SV display.

(2) Input each set value.

Input each set value, referring to “5. Setup”.

7. Alarm action explanation

7.1 High limit alarm and Low limit alarm action

	High limit alarm	Low limit alarm
Alarm action		
Alarm output		
	High limit alarm with standby	Low limit alarm with standby
Alarm action		
Alarm output		

- : A1 output terminals between 7 and 8 is connected.
- : A1 output terminals between 7 and 8 is connected or disconnected.
- : A1 output terminals between 7 and 8 is disconnected.
- : Standby functions in this section.

Use terminals 9 and 10 for A2 output, and use terminals 12 and 13 for A3 output.

A1, A2 and A3 action indicators turn on when their output terminals are connected, and turn off when their output terminals are disconnected.

7.2 High/low limit range alarm action (only for A3)

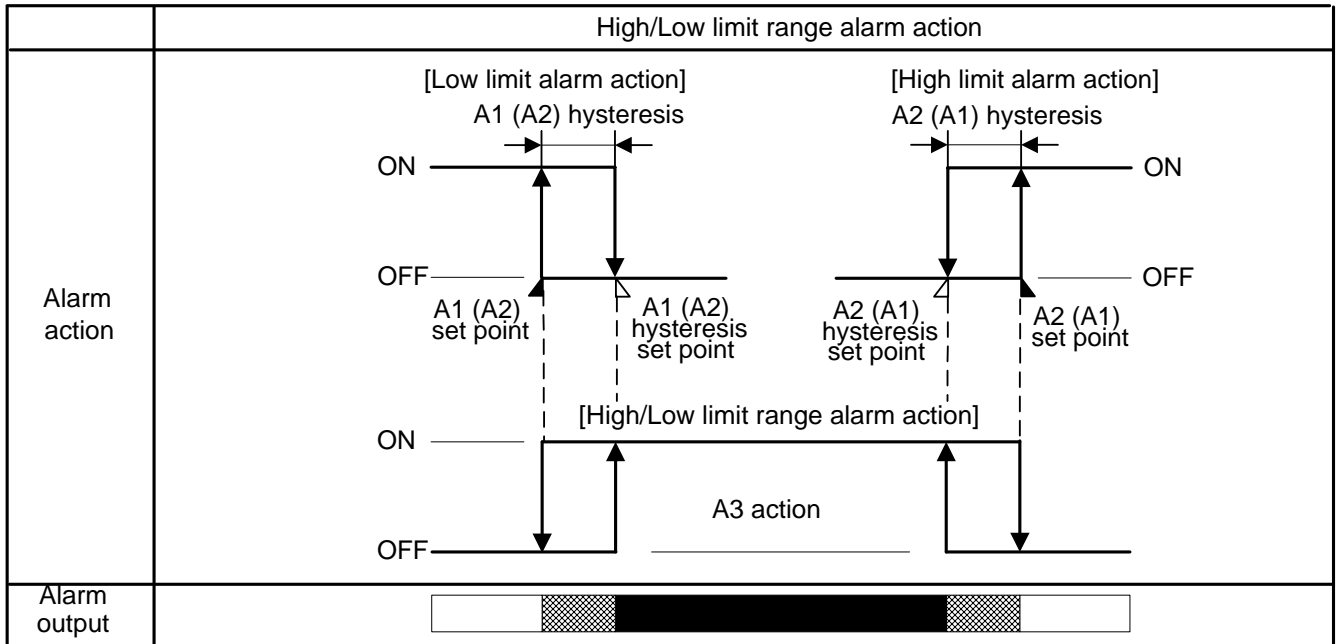

A3 High/low limit range alarm is activated depending on the status of A1 and A2 action indicators (when both A1 and A2 are OFF, A3 is ON).

So when standby function, hysteresis and action delayed timer for A1 and A2 is set, be careful about the A3 action point.

Note

- If A1 or A2 standby function is selected and while A1 or A2 standby functions, A3 is ON.
- When A1 or A2 hysteresis is increased, A3 ON span is decreased.
- When A1 or A2 action delayed timer setting (time) is increased, A3 ON time is increased.
- If A1 or A2 action delayed timer (time) is set and while A1 or A2 action delayed timer is working, A3 is ON.

: A1 output terminals between 7–8 are disconnected, A2 output terminals between 9–10 are disconnected, and A3 output terminals between 12–13 are connected.

: A1 output terminals between 7–8, A2 output terminals between 9–10 and A3 output terminals between 12–13 are connected or disconnected.

: A1 output terminals between 7–8 are connected, A2 output terminals between 9–10 are connected, and A3 output terminals between 12–13 are disconnected.

8. Specifications

8.1 Standard specifications

Mounting : Flush

Setting method : Input system using membrane sheet key

Display PV display : Red LED 4 digits, character size 16 x 7.2 mm (H x W)

SV display : Green LED 4 digits, character size 10 x 4.8 mm (H x W)

Accuracy (Setting and Indication):

Thermocouple : Within $\pm 0.2\%$ of each input span ± 1 digit, or within $\pm 2^\circ\text{C}$ (4°F), whichever is greater

However R, S inputs, 0 to 200°C (400°F): Within $\pm 6^\circ\text{C}$ (12°F)

B input, 0 to 300°C (600°F): Accuracy is not guaranteed.

K, J, E, T, N inputs, less than 0°C (32°F): Within $\pm 0.4\%$ of each input span ± 1 digit

RTD : Within $\pm 0.1\%$ of each input span ± 1 digit, or within $\pm 1^\circ\text{C}$ (2°F), whichever is greater

DC current : Within $\pm 0.2\%$ of each input span ± 1 digit

DC voltage : Within $\pm 0.2\%$ of each input span ± 1 digit

Input sampling period : 0.25 seconds

Input Thermocouple : K, J, R, S, B, E, T, N, PL-II, C (W/Re5-26) External resistance, 100Ω or less (However, B input: External resistance, 40Ω or less)

RTD : Pt100, JPt100, 3-wire system
Allowable input lead wire resistance (10Ω or less per wire)

DC current : 0 to 20mA DC, 4 to 20mA DC
 Input impedance: External shunt resistor 50Ω
 Allowable input current (50mA or less)

DC voltage : 0 to 1V DC Input impedance (1MΩ or more)
 Allowable input voltage (5V or less)
 Allowable signal source resistance (2kΩ or less)

: 0 to 5V DC, 1 to 5V DC, 0 to 10V DC Input impedance (100kΩ or more)
 Allowable input voltage (15V or less)
 Allowable signal source resistance (100Ω or less)

A1, A2 output

The alarm action point can be set at random, and if the input reaches the randomly set action point, the alarm output turns on or off corresponding to the alarm type and Energized/Deenergized selection.

Action : ON/OFF action
 Hysteresis : 0.1 to 100.0°C (°F), or 1 to 1000
 (The placement of the decimal point follows the selection)
 Output : Relay contact 1a
 Control capacity, 3A 250V AC (resistive load)
 Electric life, 100,000 times

A3 output

The alarm action point can be set at random, and if the input reaches the randomly set action point, the alarm output turns on or off corresponding to the alarm type and Energized/Deenergized selection.

The alarm action can be selected from a choice of: No alarm action, High limit alarm, Low limit alarm, High limit alarm with standby, Low limit alarm with standby and High/Low limit range alarm.

However, High/Low limit range alarm can be selected when A1 High limit alarm (High limit alarm with standby) and A2 Low limit alarm (Low limit alarm with standby) are combined, or when A1 Low limit alarm (Low limit alarm with standby) and A2 High limit alarm (High limit alarm with standby) are combined.

Action : ON/OFF action
 Hysteresis : 0.1 to 100.0°C (°F), or 1 to 1000
 (The placement of the decimal point follows the selection)
 Output : Relay contact 1a
 Control capacity, 3A 250V AC (resistive load)
 Electric life, 100,000 times

Transmission output

Converting the input value to analog signal every 0.25 seconds, outputs the value in DC current.

(When using the transmission output as an input for other instruments, check that the input impedance of these instruments is smaller than the maximum load resistance of the transmission output.)

Resolution : 1/12000
 DC current : 4 to 20mA DC (load resistance, max. 500Ω)
 Output accuracy: Within ±0.3% of output span

Power supply: 100 to 240V AC 50/60Hz, 24V AC/DC 50/60Hz

Allowable voltage fluctuation range: 100 to 240V AC : 85 to 264V AC
 24V AC/DC : 20 to 28V AC/DC

Power consumption: Approx. 10VA

Circuit insulation configuration

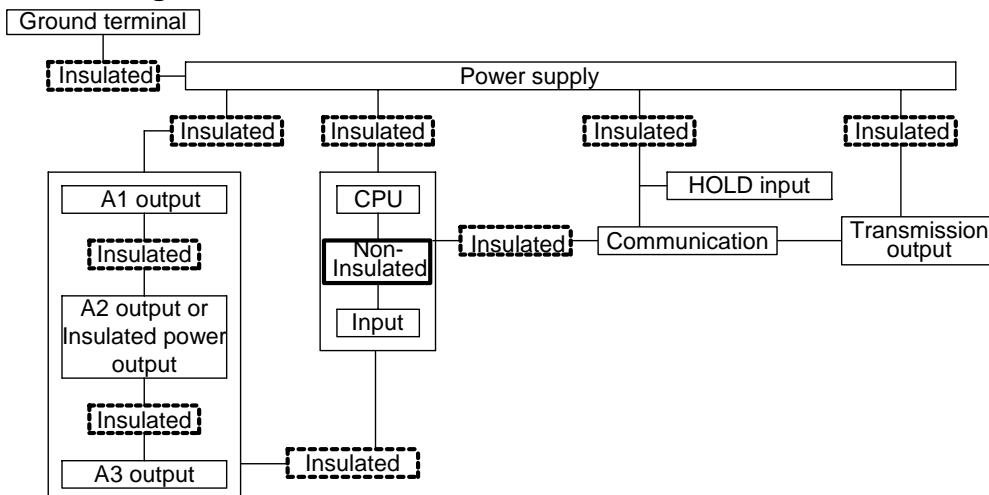

Insulation resistance : 10MΩ or more, at 500V DC

Dielectric strength : 1.5kV AC for 1 minute between input terminal and ground terminal
 1.5kV AC for 1 minute between input terminal and power terminal
 1.5kV AC for 1 minute between power terminal and ground terminal
 1.5kV AC for 1 minute between output terminal and ground terminal
 1.5kV AC for 1 minute between output terminal and power terminal
 Output terminal comprises A1, A2 and A3 output terminals, transmission output terminals and communication terminals.

Ambient temperature : 0 to 50°C (32 to 122°F)
Ambient humidity : 35 to 85%RH (non-condensing)
Weight : Approx. 300g
External dimensions : 96 x 48 x 100mm (W x H x D)
Material : Flame-resistant resin (Case)
Color : Light gray (Case)

Attached function

- [Set value lock]
- [Sensor correction]
- [Input abnormality]

Indication	Contents
Flashes [^ ^ ^ ^]	Overscale If the input value exceeds the indication range high limit value.
Flashes [- - - -]	Underscale If the input value goes under the indication range low limit value.

Thermocouple and RTD inputs

Input	Input range	Indication range
K, T	-199.9 to 400.0°C	-199.9 to 450.0°C
	-199.9 to 750.0°F	-199.9 to 850.0°F
K	-200 to 1370°C	-250 to 1420°C
	-320 to 2500°F	-370 to 2550°F
J	-200 to 1000°C	-250 to 1050°C
	-320 to 1800°F	-370 to 1850°F
R, S	0 to 1760°C	-50 to 1810°C
	0 to 3200°F	-50 to 3250°F
B	0 to 1820°C	-50 to 1870°C
	0 to 3300°F	-50 to 3350°F
E	-200 to 800°C	-250 to 850°C
	-320 to 1500°F	-370 to 1550°F
N	-200 to 1300°C	-250 to 1350°C
	-320 to 2300°F	-370 to 2350°F
PL-II	0 to 1390°C	-50 to 1440°C
	0 to 2500°F	-50 to 2550°F
C (W/Re5-26)	0 to 2315°C	-50 to 2365°C
	0 to 4200°F	-50 to 4250°F
Pt100	-199.9 to 850.0°C	-199.9 to 900.0°C
	-200 to 850°C	-210 to 900°C
	-199.9 to 999.9°F	-199.9 to 999.9°F
	-300 to 1500°F	-318 to 1600°F
JPt100	-199.9 to 500.0°C	-199.9 to 550.0°C
	-200 to 500°C	-206 to 550°C
	-199.9 to 900.0°F	-199.9 to 999.9°F
	-300 to 900°F	-312 to 1000°F

DC current and voltage inputs

If input value exceeds Indication range high limit value, PV display flashes “ ^ ^ ^ ^ ”, and if input value goes under the Indication range low limit value, the PV display flashes “ - - - - ”.

Indication range : [Scaling low limit value – Scaling span x 1%] to [Scaling high limit value + Scaling span x 10%]

(If the input value is out of the range –1999 to 9999, the PV display flashes “ ^ ^ ^ ^ ” or “ - - - - ”)

DC input disconnection: When DC input is disconnected, PV display flashes “ - - - - ” for 4 to 20mA DC and 1 to 5V DC inputs, and “ ^ ^ ^ ^ ” for 0 to 1V DC input.

For 0 to 20mA DC, 0 to 5V DC and 0 to 10V DC inputs, the PV display indicates the value corresponding with 0mA or 0V.

[Burnout]

When the thermocouple or RTD input is burnt out, PV display flashes “- - - -”.

[Self-diagnosis]

The CPU is monitored by a watchdog timer, and when any abnormal status is found on the CPU, the JIR-301-M is switched to warm-up status.

[Automatic cold junction temperature compensation] (Only thermocouple input type)

This detects the temperature at the connecting terminal between the thermocouple and the instrument, and always keeps it set to the same status as when the reference junction is located at 0°C (32°F).

[Power failure countermeasure]

The setting data is backed up in the non-volatile IC memory.

[Warm-up indication]

After the power supply to the instrument is turned on, the sensor input character and temperature unit are indicated on the PV display, and rated scale high limit value is indicated on the SV display for 3 seconds.

For DC current and voltage inputs, the scaling high limit value is indicated.

[HOLD function]

The following HOLD functions can be selected by keypad.

HOLD : By connecting terminals 14 and 17, PV at the given time is being held and indicated.

Peak HOLD : By connecting terminals 14 and 17, the updated maximum PV is indicated.

Bottom HOLD: By connecting terminals 14 and 17, the updated minimum PV is indicated.

Dust-proof/Drip-proof: IP66 (only front face)

Accessories	: Screw type mounting bracket	1 set
	Instruction manual	1 copy
	Unit label	1 label
	Terminal cover	1 piece (When the TC option is added)

8.2 Optional specifications**Specified transmission output (Option code: TA, TV)**

Converting the input value to analog signal every 0.25 seconds, outputs the value in DC current or voltage. (When using the transmission output as an input for other instruments, check that the input impedance of these instruments is smaller than the maximum load resistance of the transmission output.)

Resolution : 1/12000

Output accuracy: Within $\pm 0.3\%$ of output span

DC current : 0 to 20mA DC (Load resistance: Max. 500 Ω)

DC voltage : 0 to 1V DC (Load resistance: Min. 100k Ω)

0 to 5V DC (Load resistance: Min. 500k Ω)

1 to 5V DC (Load resistance: Min. 500k Ω)

0 to 10V DC (Load resistance: Min. 1M Ω)

Serial communication (Option code: C5)

When this option is added, HOLD function is not available.

The following operations can be carried out from the external computer.

(1) Reading and setting of the various set values

(2) Reading of the PV and action status

(3) Change of the functions

Communication interface : EIA RS-485

Communication method : Half-duplex communication start stop synchronous

Communication speed : 2400, 4800, 9600, 19200bps (Selectable by keypad) (Default: 9600bps)

Parity : Even, Odd and No parity (Selectable by keypad) (Default: Even)

Stop bit : 1, 2 (Selectable by keypad) (Default: 1)

Communication protocol : Shinko protocol, Modbus RTU, Modbus ASCII (Selectable by keypad)

Connectable number of units : Maximum 31 units to 1 host computer

Communication error detection : Double detection by parity and checksum

Data format:

Communication protocol	Shinko protocol	Modbus ASCII	Modbus RTU
Start bit	1	1	1
Data bit	7	7	8
Parity	Even	Selection (Even)	Selection (No parity)
Stop bit	1	Selection (1)	Selection (1)

Data bit is automatically selected upon selecting the communication protocol.

() : Basic set value

Insulated power output (Option code: P24)

If this option is added, A2 function is not available.

Output voltage : $24 \pm 3V$ DC (When load current is 30mA)

Ripple voltage : Within 200mV (When load current is 30mA)

Maximum load current: 30mA

Color Black (Option code: BK)

Front panel frame and case: Black



Terminal cover (Option code: TC)

Electrical shock protection terminal cover

9. Troubleshooting

If any malfunctions occur, refer to the following items after checking the power supply to the JIR-301-M.

Problem	Presumed cause and solution
<p>[- - - -] is flashing on the PV display.</p>	<ul style="list-style-type: none"> • Burnout of thermocouple, RTD or disconnection of DC voltage (0 to 1V DC). Change each sensor. How to check whether the sensor is burnt out [Thermocouple] If the input terminal of the instrument is shorted, and if a value around room temperature is indicated, the instrument is likely to be operating normally, however the sensor may be burnt out. [RTD] If approx. 100Ω of resistance is connected to the input terminals between A-B of the instrument and between B-B is shorted, and if approximate 0°C (32°F) is indicated, the instrument is likely to be operating normally, however the sensor may be burnt out. [DC voltage (0 to 1V DC)] If the input terminal of the instrument is shorted, and if a scaling low limit value is indicated, the instrument is likely to be operating normally, however, the signal wire may be disconnected. • Check whether the input terminals of thermocouple, RTD or DC voltage (0 to 1V DC) are securely mounted to the instrument input terminals. Ensure that the sensor terminals are securely connected to the instrument input terminals.
<p>[- - - -] is flashing on the PV display.</p>	<ul style="list-style-type: none"> • Check whether input signal source for DC voltage (1 to 5V DC) or DC current (4 to 20mA DC) is disconnected. How to check whether the input signal wire is disconnected [DC voltage (1 to 5V DC)] If the input to the input terminals of the instrument is 1V DC and if a scaling low limit value is indicated, the instrument is likely to be operating normally, however, the signal wire may be disconnected. [DC current (4 to 20mA DC)] If the input to the input terminals of the instrument is 4mA DC and if a scaling low limit value is indicated, the instrument is likely to be operating normally, however the signal wire may be disconnected. • Check whether the input signal wire for DC voltage (1 to 5V DC) or DC current (4 to 20mA DC) is securely connected to the instrument input terminals. Ensure that the input signal wire is securely connected to the instrument input terminals. • Check whether polarity of thermocouple or compensating lead wire is correct. Check whether codes (A, B, B) of the RTD agree with the instrument terminals. Ensure that they are wired properly.

<p>The PV display keeps indicating the value which was set during Scaling low limit setting.</p>	<ul style="list-style-type: none"> • Check whether the input signal source for DC voltage (0 to 5V DC, 0 to 10V DC) and DC current (0 to 20mA DC) is disconnected. How to check whether the input signal wire is disconnected [DC voltage (0 to 5V DC, 0 to 10V DC)] If the input to the input terminals of the instrument is 1V DC and if the value corresponding to 1V DC is indicated, the instrument is likely to be operating normally, however, the signal wire may be disconnected. [DC current (0 to 20mA DC)] If the input to the input terminals of the instrument is 1mA DC and if the value corresponding to 1mA DC is indicated, the instrument is likely to be operating normally, however, the signal wire may be disconnected. • Check whether the input lead wire terminals for DC voltage (0 to 5V DC, 0 to 10V DC) or DC current (0 to 20mA DC) are securely mounted to the instrument input terminals.
<p>The indication of the PV display is abnormal or unstable.</p>	<ul style="list-style-type: none"> • Check whether the sensor input or temperature unit (°C or °F) is correct. Select the sensor input and temperature unit (°C or °F) properly. • Sensor correcting value is unsuitable. Set it to a suitable value. • Check whether the specification of the sensor is correct. • AC leaks into the sensor circuit. Use an ungrounded type sensor. • There may be equipment that interferes with or makes noise near the JIR-301-M. Keep equipment that interferes with or makes noise away from the JIR-301-M.
<p>The PV display is indicating [Err].</p>	<ul style="list-style-type: none"> • Internal memory is defective. Contact our agency or us.
<p>The value on the PV display does not change.</p>	<ul style="list-style-type: none"> • Check whether HOLD function is working. Release the HOLD function.
<p>The values do not change by  or  key.</p>	<ul style="list-style-type: none"> • Set value lock (Lock 1 or Lock 2) is selected. Release the lock selection.

• For all other malfunctions, please contact our main office or dealers.

**SHINKO TECHNOS CO., LTD.
OVERSEAS DIVISION**

Reg. Office : 2-5-1, Senbahigashi, Minoo, Osaka, Japan

URL : <http://www.shinko-technos.co.jp>

E-mail : overseas@shinko-technos.co.jp

Tel : 81-72-727-6100

Fax: 81-72-727-7006